

Emergency Eye/Face Wash Pedestal Mounted Hand/Foot Operated

Enware's emergency eye/face wash units help to flush contaminants and irritants from eyes and facial area.

EFE390

Designed and manufactured in Australia. Stainless steel construction provides superior durability and reliability.

FEATURES

- Independently tested for compliance to ANSI Z358.1 and AS4775
- Freestanding for stand-alone operation
- Stainless steel bowl, stay-open ball valve and hand actuator
- Integral volume adjustment control
- Hand push and foot activated eye/face wash with integral auto-open dust covers
- Zero velocity apex point provides more comfort and control for effective cleansing of eyes
- Eye/face wash features "Vertech™ Technology" where dedicated eye wash and independently angled face wash streams deliver optimum coverage
- Solid stainless, low angle foot pedal for easy activation of eye/face wash
- High visibility yellow powder coated push handle and foot pedal

ADDITIONAL OPTIONS:

- Audio/Visual alarms for alerts
- Flow pressure & proximity switches to activate alarms and lights
- Thermal relief valve removes built-up hot water
- Insulation of pipe work to moderate water temperature build up
- Anti-freeze valve for cold weather climates to help prevent water freezing
- NPT flange connectors
- Custom manufacturing & design
- Signage compliant to AS1319



Product Codes

EFE390	Standard Brushed Stainless Steel Finish
EFE390GR	Green Powder Coated Finish
EFE390OR	Orange Powder Coated Finish
EFE390YE	Yellow Powder Coated Finish
EFE390WH	White Powder Coated Finish

Technical Information

Inlet Connection	15 mm (1/2") BSP
Water Supply Line Size	Must be hydraulically sized to meet requirements.
Minimum Performance Requirements	210 kPa Caution should be taken when pressure exceeds 550 kPa (80 psi)
Minimum Flow Requirements	26 lpm (6.9 US gpm)
Waste Water Outlet Size	38 mm (1 1/2") OD
Mounting Base Plate Size	150 x 150 mm (5 9/10" x 5 9/10") with 4 Bolt Holes 11 mm (7/16")
Weight	approx. 9kg
Dimensions	1160 x 300 x 250 mm

Installation of emergency showers, eye and eye/face wash equipment shall be in accordance with AS/NZS4775-2007 or ANSI Standard Z358.1 - whichever is applicable to the installation. Enware Australia advises:

- Due to ongoing Research and Development, specifications may change without notice.
- Component specifications may change on some export models.

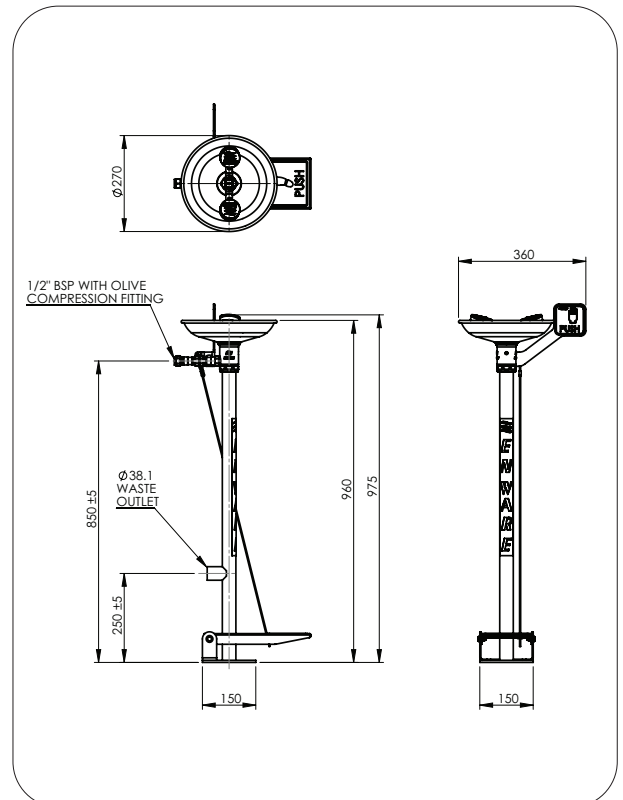

Version: May 21

Call 1300 369 273
www.enware.com.au

Enware Australia Pty Limited
9 Endeavour Rd Caringbah NSW 2229 Australia
Ph: 02 8536 4000 info@enware.com.au



ECE Range Spare Parts

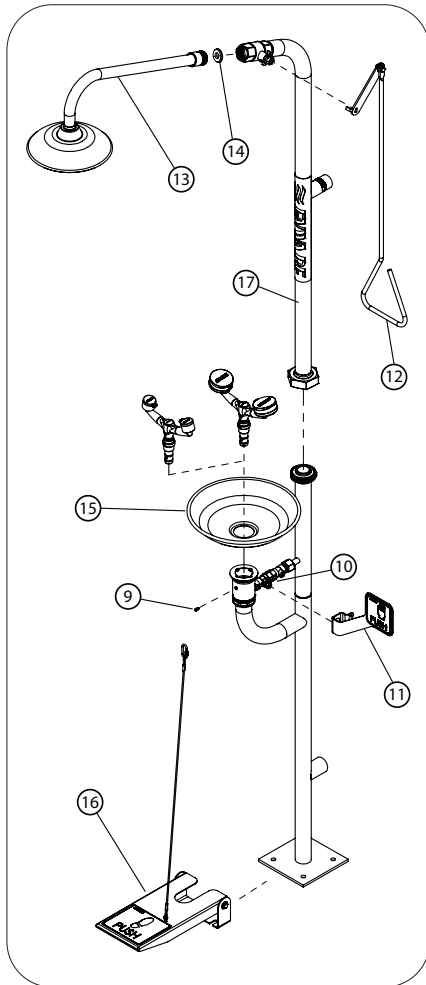
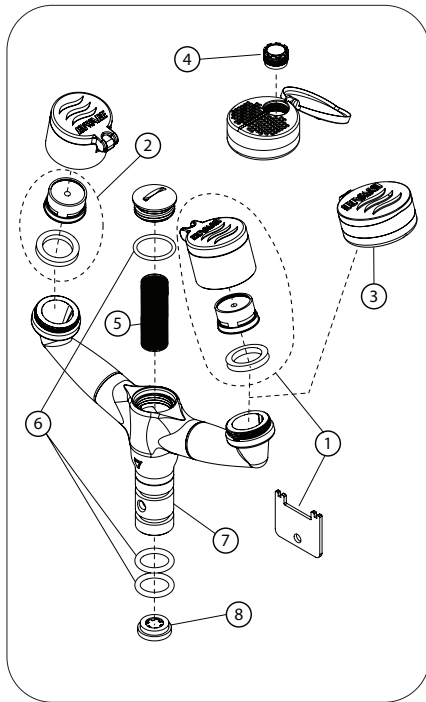

	DESCRIPTION	ORDER CODE	
1	Eye wash dust cover with aerator (1 pair) and key	ESPE016	
2	Aerator and washer (1 each) for eye wash	ESPE015	
3	Eye/face wash outlet (each) incl. aerator	ESPE012	
4	Aerator to suit eye/face wash (each) - (Cache TJ 7.5 Lpm)	ESPE013	
	Aerator key to suit eye/face wash	ESPE014	
5	Mesh filter (40 mesh)	ESPE811	
6	O-rings for eye wash & eye/face wash tee piece (2x spigot, 1x strainer cap O-rings)	ESPE812	
7	Eye wash & eye/face wash frame only incl. grub screw, mesh filter, O-rings *	ESPE815	
7	Eye wash & eye/face wash frame only - Retrofit model to replace old type *	ESPE002 RETRO	
8	Flow control insert for eye wash (brown 17 L/min)	ESPE003	
8	Flow control insert for eye/face wash (red 26.5 L/min)	ESPE004	
9	Grub screw for eye wash & eye/face wash frame	ESPE814	

	DESCRIPTION	ORDER CODE	
10	Ball valve for eye wash & eye/face wash *	ESP005	
11	Push handle to suit eye wash & eye/face wash	ESPE010	
12	Pull handle to activate shower	ESPE009	
13	Shower arm and rose incl. flow control orifice disc *	ESPE005	
14	Flow control orifice disc for shower rose	ESP042	
15	Bowl only * (not suitable for ENBE models)	ESPE008	
16	Foot operation conversion kit for eye wash & eye/face wash	ESPE001	
	Inspection tag	ESS521	
	Eye wash tester gauge	EST101	
	Shower tester anti-static	EST100	
17	Shower frame top section with ball valve *	ESPE006	

* Powder coat options available

Version: May 21

Call 1300 369 273
www.enware.com.au

Enware Australia Pty Limited
9 Endeavour Rd Caringbah NSW 2229 Australia
Ph: 02 8536 4000 info@enware.com.au

